



CLIP[™] Cartridge Lip Seal



- DRY RUNNING CARTRIDGE SEAL
- SUPPLIED WITH QUENCH AND DRAIN ENVIRONMENTAL PORTS
- EXTERNALLY MOUNTED

CLIP™ - Cartridge Lip Seal design

The AESSEAL® CLIP™ seal is specifically designed for dry running applications where barrier fluid is not permitted to enter the process media.

This makes the design ideally suited for slow rotating equipment in the food and pharmaceutical industries. Typical applications include the Viking Universal, 124-125 and 4124-4125 pump ranges.

The seal design uses the latest monolithic Graphite impregnated PTFE lip seal technology. This reduces lip seal wear and debris, thereby helping to increase seal life.

Other design features include:

- Hard plated cartridge sleeve extends lip seal life.
- Factory assembled and tested.
- Replaceable cartridge sleeve eliminates shaft wear.
- Ease of lip seal repair. The monolithic lip seal unit eliminates separate lip seal rings and spacers.

Dry Running Performance:

The seal design is offered for shaft speeds up to 3.3m/s (650ft/min).

Lubricated Fluid Running Performance:

The seal design is offered for shaft speeds up to 9.6m/s (1,900ft/min) under TRUE lubricated conditions.

Please consult AESSEAL® Technical Department for applications which exceed these shaft speeds.

Complementary Gas Panel Seal Support Systems

To complement the dry running capability of the CLIP seal design, AESSEAL® offer a modular range of Gas Panel Seal Support Systems (Figure 1). These Gas Panels have a number of features to ensure a consistent and controlled flow of pressurised gas barrier to the mechanical seal faces.

Please contact your local AESSEAL® representative to discover more about the Gas Panel Systems.

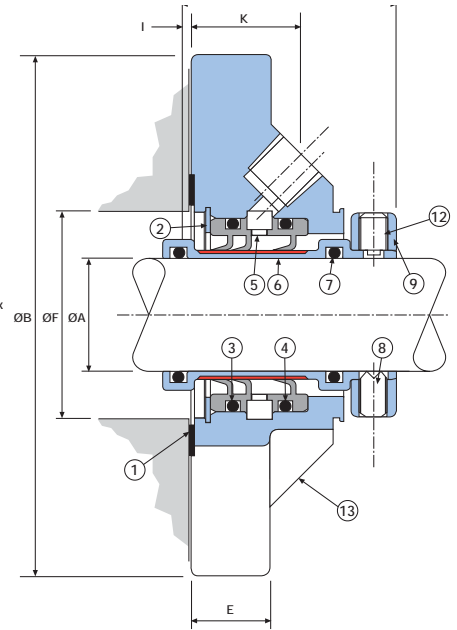
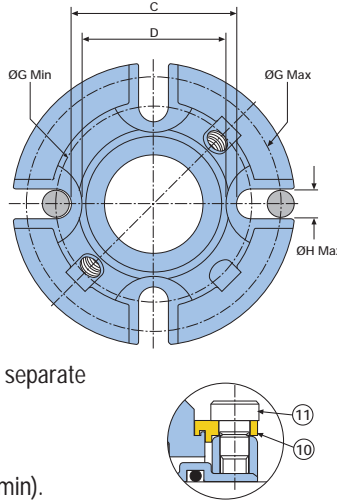

CLIP Seal Labeling

Item	Description	Material
1	Gasket	AF1 / GFT
2	Circlip	Stainless Steel
3	O Ring	Viton® / EPR / Kalrez® / Aflas®
4	O Ring	Viton® / EPR / Kalrez® / Aflas®
5	Lipseal	Graphite PTFE
6	Sleeve	316L Stainless Steel - Cr.Ox.
7	O Ring	Viton® / EPR / Kalrez® / Aflas®
8	Drive Screws	Stainless Steel
9	Clamp Ring	316L Stainless Steel
10	Setting Clips	Brass
11	Clip Screws	Stainless Steel
12	Anti Tamper Screws	Stainless Steel
13	Gland	316 Stainless Steel

CLIP Seal Dimensional Information (Inches)

Seal Size	ØA	ØB	C	D	E	ØF Max	ØG Min	ØG Max	H	I	J	K
1.437	1.437	4.000	2.870	n/a	1.055	2.312	3.375	3.562	0.438	0.120	1.625	0.570
1.500	1.500	4.990	2.812	2.562	0.644	2.375	3.375	4.437	0.500	0.050	1.710	0.933
1.625	1.625	4.990	2.812	2.562	0.644	2.500	3.375	4.437	0.500	0.050	1.710	0.933
2.437	2.437	6.687	4.312	3.812	0.769	3.625	5.000	6.062	0.625	0.060	1.875	1.129
2.500	2.500	6.990	4.312	3.812	0.769	3.625	5.000	6.312	0.625	0.060	1.875	1.129



Figure 1

THIS DOCUMENT IS DESIGNED TO PROVIDE DIMENSIONAL INFORMATION AND AN INDICATION OF AVAILABILITY. FOR FURTHER INFORMATION AND SAFE OPERATING LIMITS CONTACT OUR TECHNICAL SPECIALISTS AT THE LOCATIONS BELOW.



USE DOUBLE MECHANICAL SEALS WITH HAZARDOUS PRODUCTS. ALWAYS TAKE SAFETY PRECAUTIONS:

- GUARD YOUR EQUIPMENT
- WEAR PROTECTIVE CLOTHING



UK Sales & Technical advice:
 AESSEAL plc
 Mill Close
 Templeborough
 Rotherham
 S60 1BZ
 United Kingdom
 Telephone: +44 (0) 1709 369966
 Fax: +44 (0) 1709 720788
 E-mail: seals@aesseal.com
 Internet: http://www.aesseal.com

Distributed by:

Our Purpose: *'To give our customers such exceptional service that they need never consider alternative sources of supply.'*

USA Sales & Technical advice:
 AESSEAL Inc.
 355 Dunavant Drive
 Rockford, TN. 37853
 USA
 Telephone: +1 865 531 0192
 Fax: +1 865 531 0571
 E-mail: usa@aesseal.com

ALL SIZES ARE SUBJECT TO MANUFACTURING TOLERANCES. WE RESERVE THE RIGHT TO MODIFY SPECIFICATIONS AT ANY TIME.

AESSEAL plc recognise all trademarks and trademark names as the property of their owners.

CLIP™ is a Trademark of AESSEAL plc.
 Registered Trademarks: AESSEAL® - AESSEAL plc
 Viton®, Kalrez® - DuPont Dow Elastomers, Aflas® - Asahi Glass Co.